

## 650V Planar SiC Power MOSFET

Parameter	Value	Unit
$V_{DS}$	650	V
$R_{DS(on\_typ.)}$ $V_{GS}=15V$	180	m $\Omega$
$I_D$	15	A

### Features

- Wide Bandgap SiC MOSFET Technology
- Low On-Resistance with High Blocking Voltage
- Low Capacitances with High-Speed Switching
- Low Reverse Recovery (Qrr)
- Robust against Parasitic Turn on Even 0V Turn off Gate Voltage

### Benefits

- Reduced Switching Losses
- Increased System Switching Frequency
- Increased Power Density
- Reduction of Heat Sink Requirements
- Reduced EMI

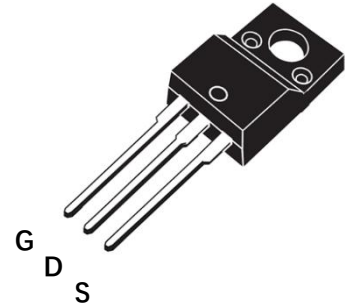

TO-220F-3L TopView

### Application

- Switch Mode Power Supplies
- High Voltage DC/DC Converters
- Battery Chargers
- Motor Drives
- Pulsed Power Applications

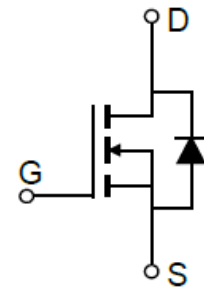

Schematic Diagram

### Package parameters

Part Number	Marking	Package	Packaging Method
GSA180R065MC	GSA180R065MC	TO-220F-3L	Tube

## Maximum ratings at $T_j=25^\circ\text{C}$ , Unless otherwise specified

Parameter	Symbol	Test Condition	Value	Unit
Drain to Source Voltage	$V_{DS}$	$V_{GS} = 0V, I_D = 100\mu\text{A}$	650	V
Gate to Source Voltage	$V_{GS}$	Absolute maximum values	-10/+22	V
Recommended Operation Voltage of Gate to Source	$V_{GSop}$	Recommended operational values	0/+18	V
Continuous Drain Current	$I_D$	$V_{GS}=15V, T_C=25^\circ\text{C}$	15	A
		$V_{GS}=15V, T_C=100^\circ\text{C}$	10	
Pulsed Drain Current	$I_{DM}$	$V_{GS}=15V, T_C=25^\circ\text{C}$	30	A
Power Dissipation	$P_{tot}$	$T_C=25^\circ\text{C}, T_j=175^\circ\text{C}$	42	W
Operating and Storage Temperature	$T_j, T_{stg}$		-55 to +175	$^\circ\text{C}$

## Thermal Characteristics

Parameter	Symbol	Value			Unit
		Min.	Typ.	Max.	
Thermal Resistance from Junction to Case	$R_{th(j-c)}$	-	3.6	-	$^\circ\text{C}/\text{W}$

## Electrical Characteristics

### Static Characteristics

Parameter	Symbol	Test Condition	Value			Unit
			Min.	Typ.	Max.	
Drain to Source Breakdown Voltage	$V_{(BR)DSS}$	$V_{GS}=0V, I_D=500\mu\text{A}$	650			V
Gate Threshold Voltage	$V_{GS(th)}$	$V_{GS} = V_{DS}, I_D=3.5\text{mA}$	2.7		4.5	V
Zero Gate Voltage Drain Current	$I_{DSS}$	$V_{GS}=0V, V_{DS}=650V, T_j=25^\circ\text{C}$			10	$\mu\text{A}$
Gate to Source Leakage Current	$I_{GSS}$	$V_{GS}=18V, V_{DS}=0V$			250	nA
Drain to Source on Resistance	$R_{DS(on)}$	$V_{GS}=15V, I_D=8.5\text{A}$		180	240	m $\Omega$
		$V_{GS}=15V, I_D=8.5\text{A}, T_j=175^\circ\text{C}$		160		
		$V_{GS}=18V, I_D=8.5\text{A}$		120		
		$V_{GS}=18V, I_D=8.5\text{A}, T_j=175^\circ\text{C}$		130		

## Dynamic Characteristics

Parameter	Symbol	Test Condition	Value			Unit
			Min.	Typ.	Max.	
Input Capacitance	$C_{iss}$	$V_{GS}=0V, V_{DS}=500V, f=1MHz,$ $T_j=25^\circ C$		491		pF
Output Capacitance	$C_{oss}$			39		
Reverse Transfer Capacitance	$C_{rss}$			4.2		
Total Gate Charge	$Q_g$	$V_{GS}=0/15V, V_{DS}=500V, I_D=8.5A,$ $T_j=25^\circ C$		28.6		nC
Gate-Source Charge	$Q_{gs}$			13.8		
Gate-Drain Charge	$Q_{gd}$			8.3		
Gate Resistance	$R_g$	$V_{AC}=25mV, f=1MHz$		3.3		$\Omega$

## Switching Characteristics

Parameter	Symbol	Test Condition	Value			Unit
			Min.	Typ.	Max.	
Turn-On Delay Time	$t_{d(on)}$	$V_{GS}=0/15V, V_{DD}=500V,$ $I_D=8.5A, R_g=10\Omega$		16		ns
Rise Time	$t_r$			55		
Turn-Off Delay Time	$t_{d(off)}$			34		
Fall Time	$t_f$			71		

## Reverse Diode Characteristics

Parameter	Symbol	Test Condition	Value			Unit
			Min.	Typ.	Max.	
Diode Forward Voltage	$V_{SD}$	$V_{GS}=0V, I_{SD}=5A, T_j=25^\circ C$	-	3.4		V
Continuous Diode Forward Current	$I_S$	$V_{GS}=0V, T_j=25^\circ C$		15		A
Reverse Recovery Time	$t_{rr}$	$V_{GS}=0V, I_{SD}=8.5A,$ $V_R=500V, di/dt=530A/us, T_j=25^\circ C$		17.6		ns
Reverse Recovery Charge	$Q_{rr}$			43		nC
Peak Reverse Recovery Current	$I_{rrm}$			4.2		A

## Typical Performance

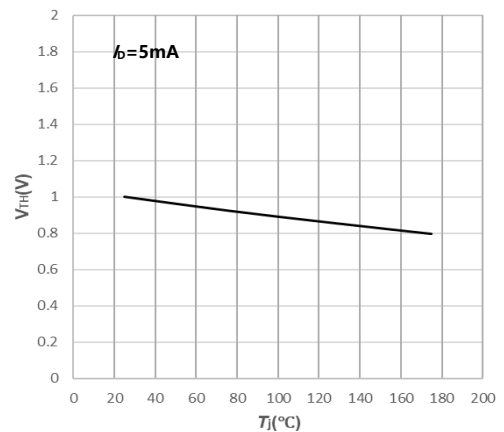
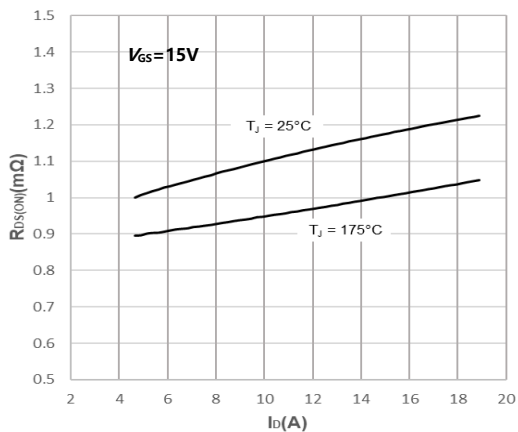
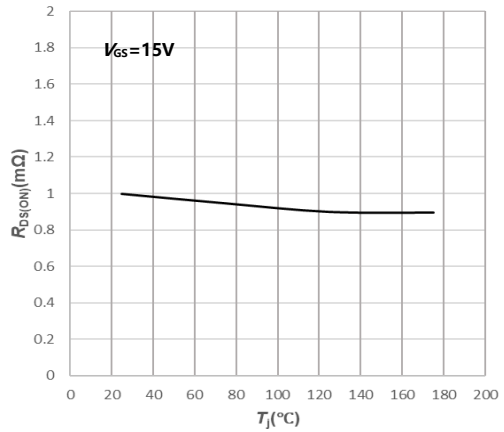
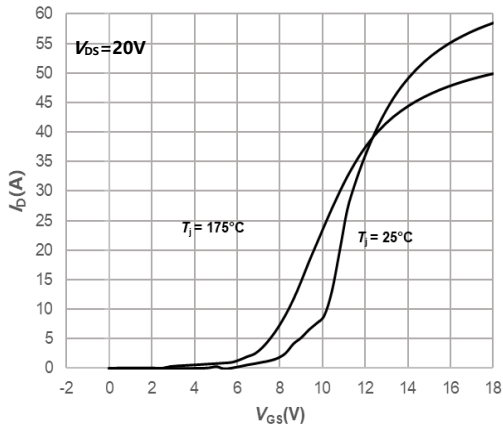
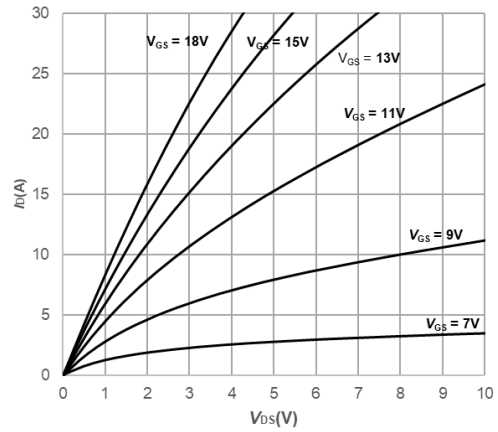
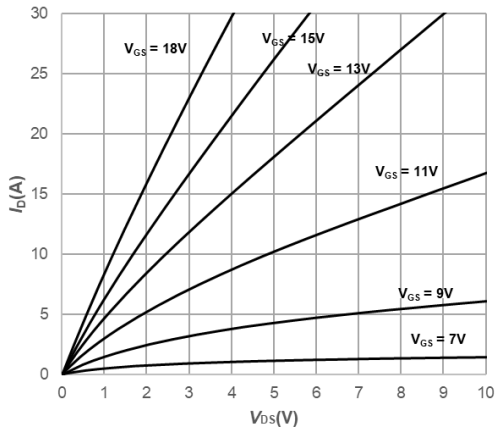

## Typical Performance

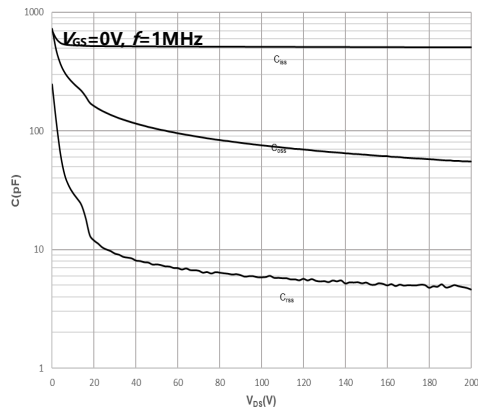

Fig7. Capacitances vs. Drain-Source Voltage (0-200V)

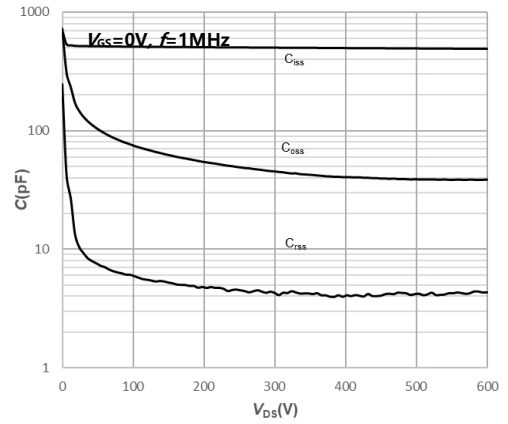

Fig8. Capacitances vs. Drain-Source Voltage (0-600V)

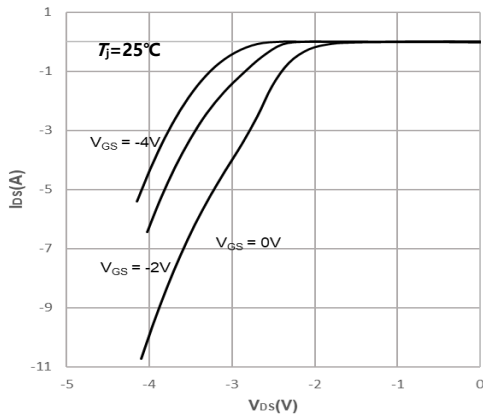
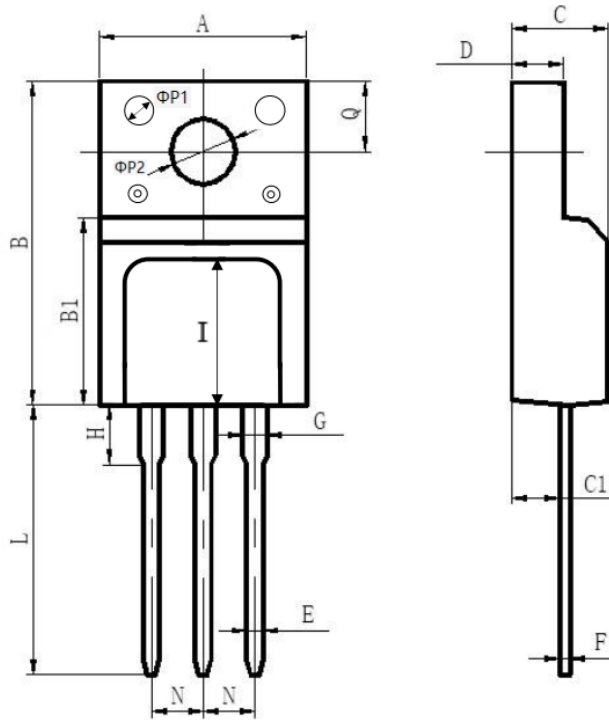

Fig9. Body Diode Characteristics

# GSA180R065MC

## TO-220F-3L Package Dimensions



Ref.	Dimensions(mm)	
	MIN	MAX
A	9.70	10.30
B	15.50	16.10
B1	8.99	9.39
C	4.40	4.80
C1	2.15	2.55
D	2.44	2.64
E	0.70	0.90
F	0.40	0.60
G	1.12	1.42
H	3.40	3.80
I	7.40	7.60
L	12.6	13.6
N	2.34	2.74
Q	3.15	3.55
ΦP1	1.40	1.60
ΦP2	3.00	3.30

## Disclaimer

Groupsemi reserves the right to make changes of the information contained herein at any time without notice.

Groupsemi exerts the greatest possible effort to ensure high quality and reliability. Nevertheless, semiconductor devices in general can malfunction or fail due to their inherent electrical sensitivity and vulnerability to physical stress. It is the responsibility of the buyer, when utilizing Groupsemi products, to comply with the standards of safety in making a safe design for the entire system to prevent any accidents, fires, or community damage that may ensue. In developing your designs, please ensure that Groupsemi products are used with specified operating ranges as set forth in the most recent Groupsemi products specifications.

The Groupsemi products listed in this document are intended for usage in general electronics applications. These Groupsemi products are neither intended nor warranted for usage in equipment that requires extraordinarily high quality and/or reliability or a malfunction or failure if which may cause loss of human life or bodily injury, such as medical instruments, transportation instruments, combustion control instruments, atomic energy control instruments, airplane or spaceship instruments etc. all types of safety devices.

## Reversion History

Rev.	Date	Change Description
1.0	2025-06-15	Form the initial version
1.1	2025-08-20	Update electrical parameter